

PANTHER T8



PAYLOAD
16,000 lb • 7,257 kg



SPEED
7.15 mph • 11.5 km/h



CAPACITY
5.75 yd³ • 4.45 m³



ENGINE

Make/Model/Type	Caterpillar C7.1 Diesel engine	
Emission Level	EPA Tier 4 Final/ EU Stage V	
Max Power Output	225 HP @2200 rpm	168 kW @2200 rpm

TRANSMISSION

Hydrostatic variable displacement pumps and motors

UNDERCARRIAGE

Track Type	Metal-embedded rubber track (MERT)	
Track Width	27.6 in	700 mm
Ground Clearance	17.2 in	437 mm
Ground Pressure		
without load	2.80 psi	19.31 kPa
with load	4.70 psi	32.41 kPa

BRAKE

Service Brake	Wet Multiple Disk Brakes	
---------------	--------------------------	--

PERFORMANCE

Payload Dump Body	16,000 lb	7,257 kg
Payload Bare Chassis	19,138 lb	8,681 kg
Operating Weight		
Unloaded Dump Body	23,910 lb	10,845 kg
Travel Speed	7.15 mph	11.5 km/h
Dump Body Capacity		
Struck	4.3 yd ³	3.3 m ³
Heaped	5.75 yd ³	4.45 m ³
Maximum Gradeability		
Uphill/Downhill	60%	31°
Side hill	40%	21.8°

FLUID CAPACITIES

Diesel Fuel	65 gal (US)	245 l
DEF / AdBlue [†]	7.1 gal (US)	27 l

ELECTRICAL SYSTEM

Voltage	12 V	
Alternator Capacity	150 A	
Battery Capacity	1150 CCA (two)	

EQUIPMENT

STANDARD EQUIPMENT • BARE CHASSIS

Operator environment

Spacious wide cab – 1 person
Tilt and telescopic steering wheel
Foot throttle pedal
Operator seat with suspension and adjustments
Air conditioning
Adjustable temperature, fan control and fresh air intake
Three-point seat belt
Front and rear wipers with adjustable speeds
Windshield washer
Two exterior mirrors (right-side remotely adjustable)
Main display 4.3 in (111 mm)

Safety

Parking brake linked to seat belt
Side window emergency exit
ROPS ISO 3471
Back-up alarm
Horn
First aid kit
Fire extinguisher

Electrical and Lighting

Working lights, LED (two front, one rear)
Batteries maintenance-free (two)
Battery disconnect switch

Other

Pressurized hydrostatic oil tank
Lockable compartments for fluids and batteries
D-ring for transportation (four)
Lockable door
Spare parts catalog
Operating and maintenance manuals

OPTIONAL EQUIPMENT

Dump body	Flashing LED beacon light	Engine coolant heater
Tilt deck	Inclinometer built into display with adjustable alarms	Front frame extensions
Trainer seat	Heated mirrors	Front winch 20,000 lb / 9,072 kg
Narrow cab - 1 person	Front brushguard	Power take off adaptors
Bluetooth Radio, USB and AM/FM	FOPS ISO 3449	Implement-ready Electronic kit
Rear view camera	Engine block and hydraulic oil heaters	

DIMENSIONS

A	110.2 in	2,800 mm
B	95 in	2,412 mm
C	67.4 in	1,712 mm
D	17.2 in	437 mm
E	27.6 in	700 mm
F	223.7 in	5,681 mm

G	188.9 in	4,799 mm
H	161.1 in	4,093 mm
I	38.4 in	975 mm
J	100.6 in	2,555 mm
K	28.9 in	735 mm
L	52.7 in	1,338 mm

M	65.8 in	1,671 mm
N	168.9 in	4,290 mm
a1	30°	
a2	34°	
a3	64°	

Dump Body Width	83 in	2,107 mm
Dump Body Length	125.3 in	3,183 mm

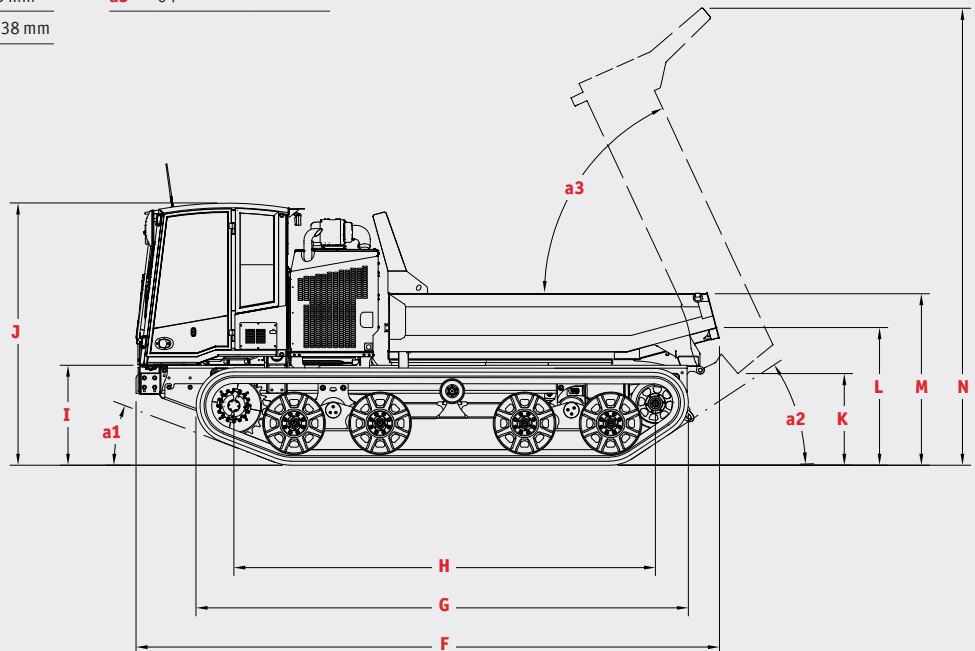
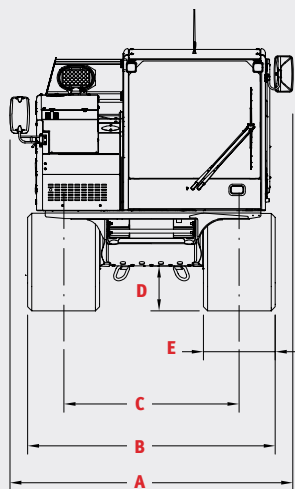

PRINOTH Ltd., 1001 J.-A. Bombardier Street, Granby QC J2J 1E9, CANADA

Service: 450-776-3663 after.sales.service.na@prinoth.com

Parts: 1-866-776-3636 parts.na@prinoth.com

Sales: 450-776 3600 sales.na@prinoth.com